

# Off Grid LED Solar Flood Light

# User Manual

RP-SFL-20W-40K-BK-G1

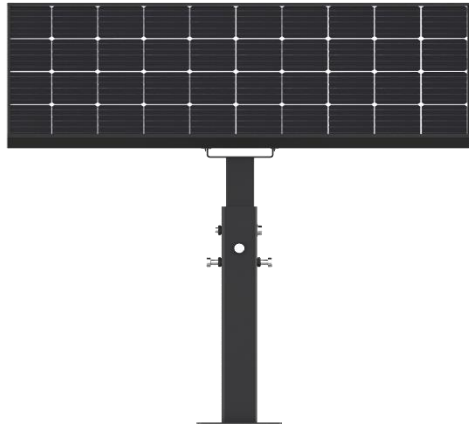

20W / 2000 LM

RoHS CE FC  

# Product Information

Product Model	RP-SFL-20W-40K-BK-G1
Actual Power/ Lumen	20W / 2000LM
Dimension L x W x H	Main body: 25.8 x 10.55 x 3.23 in Support plate: 4.72 * 4.72 in, Height adjustable: 16.34~21.1 in
LED rated life	>50,000 HRS
Lithium Ion Battery	7.4V 20Ah
Solar Panel	12V 26W Polycrystalline
Working Mode	4 hrs. at 100% full brightness then 25% brightness for the remainder of the night +Intelligent power adjustment (50%)
Color Temperature	4000K
Material	Aluminum Alloy + Polycarbonate
Charge Time	Around 8-9 hours of sunlight
Beam Angle	50° x 80°
IP Degree	IP65
Recommended Install Height	n/a
Weight	15.4 lbs
Warranty	3 YEARS
Packing	QTY/CTN: 1pc
Battery Charing Temp	Charging Temperature 32°F ~ 113°F Discharging Temperature -4°F ~ 140°F
Fixture Operating Temp	-4°F ~ 140°F

## Features:

- Easy installation- no electrical wiring required with integrated design.
- Turns on automatically at night and off during the day.
- The lights include an On/ Off switch and built in battery.
- Battery can support 5-6 nights with cloudy days.
- When the battery is full charged in sunlight, the lights will operate up to 5 nights.
- Intelligent power saving mode increases lighting x 1.5 times.
- IP65 water and dust resistance.

## Applications:

- Sculpture/Memorial
- Billboard/sign
- Pathway
- Sign boards
- Wall washer
- Garden feature
- Commercial product

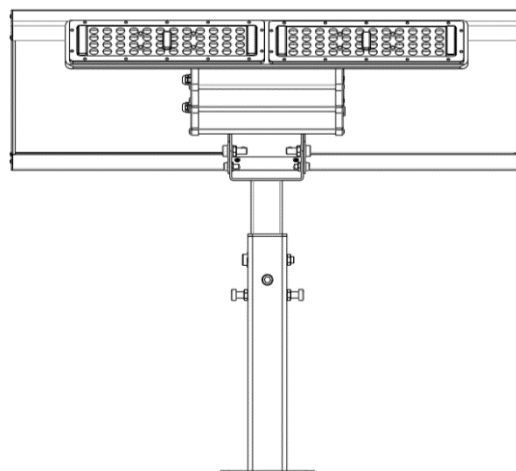
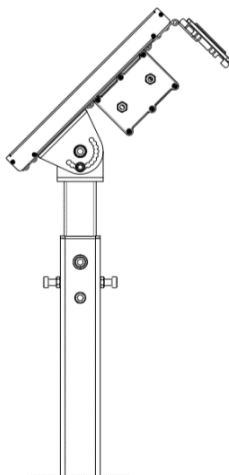

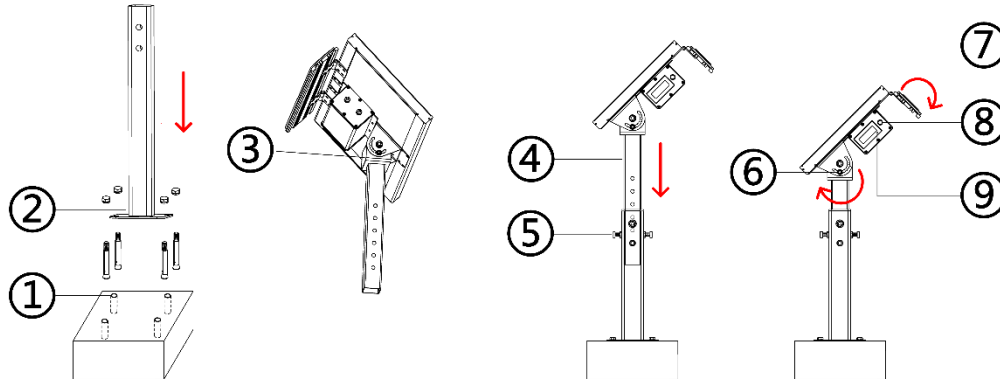

1. Using the base plate as a template, mark and drill 4x holes (size 12 \* 75mm) and insert the Anchor Bolts provided.

2. Install the base mounting plate over the four bolts, ensuring the unit is square and straight. Insert the washer and nut over the Anchor bolts and tighten.

3. Install the light fixture with the rotatable pole with scale holes.

4. Adjust the height of the telescopic mount to ensure the lamp is at the right illumination height.

5. Insert one bolt to fix height and other 4 bolts to tighten from four sides.

6. Rotate the light fixture to enable best angle for projection.

7. Adjust the LED light panel to the appropriate angle and tighten.

8. Turn on the main power button to activate the whole solar lighting system under the solar panel.

9. ON/OFF of LED display to show battery capacity.

#### Notes:

- All screws and bolts must be tightened firmly.
- Only press the main power button once. The light will operate automatically at night.
- Please charge the product for 6-8h before use.
- The solar light will automatically turn off when it detects low voltage from the battery. This may happen after 5-6 cloudy days. For best charging performance, please place light in direct sunlight.
- To test the light during daylight hours, fully cover the solar panel and press the main power button.

## HOW THE SOLAR PANEL WORKS

During the day, the solar panel converts sunlight into electricity to charge the battery. At night, the lights turn ON automatically using the electricity stored in the battery. The performance of the solar lights is dependent on the location of the solar panel and/ or weather conditions.

Install the solar panel in a sunny position ensuring it receives 6-8 hours sunlight each day.

Reduced sunlight will reduce continuous working hours at night.

**Please note:** during continuous wet & overcast days, lighting time may be reduced as the battery will not be fully charged. The lights may stop working during longer rainy periods of more than 5 days & will return to normal function when the sun returns. After an extended period of poor weather restore the battery power by turning the unit off and, fully charge the battery for 8 hours in full sunlight.

### 8.Changing Battery Pack:

To replace exhausted battery packs on this model you will need to:

1. Unscrew the black control box at the rear of the solar panel by removing all 4 bolts.
2. Unplug both solar panel cable and light cable by unscrewing the waterproof connectors then pull firmly on opposite plug ends.
3. When requesting a replacement battery compartment from Solar we will include a return label free of charge for your exhausted unit. Solar will service and recycle these parts.
4. Once you have the replacement control box, re-attach to rear of solar panel and tighten the 4 bolts.
5. Match up the correct cable connectors with their corresponding partner plug, then screw up the waterproof cover. (if the cover does not screw up easily, then the connectors are not fully pressed together)
6. Allow the Sunray unit to charge over 2 full sunny days (longer if overcast weather), then engage ON button for standard operation.
7. Test the unit by covering the solar panel fully during daylight hours. The light should operate automatically.

With the unit still turned ON, remove the cover exposing the solar panel to UV light. The light should turn OFF automatically.

This test will confirm the light is operating normally and can be returned to full service.

**Note:** This product uses a series of 7.4V, 2000mAh rechargeable lithium battery

**BATTERY WARNINGS** – Do not dispose of batteries in regular household waste. Do not get the batteries wet, hot or in contact with flames. Dispose of batteries at your local battery recycle center. Do not expose to flames or other corrosive material. Follow aviation safety guidelines where applicable.